

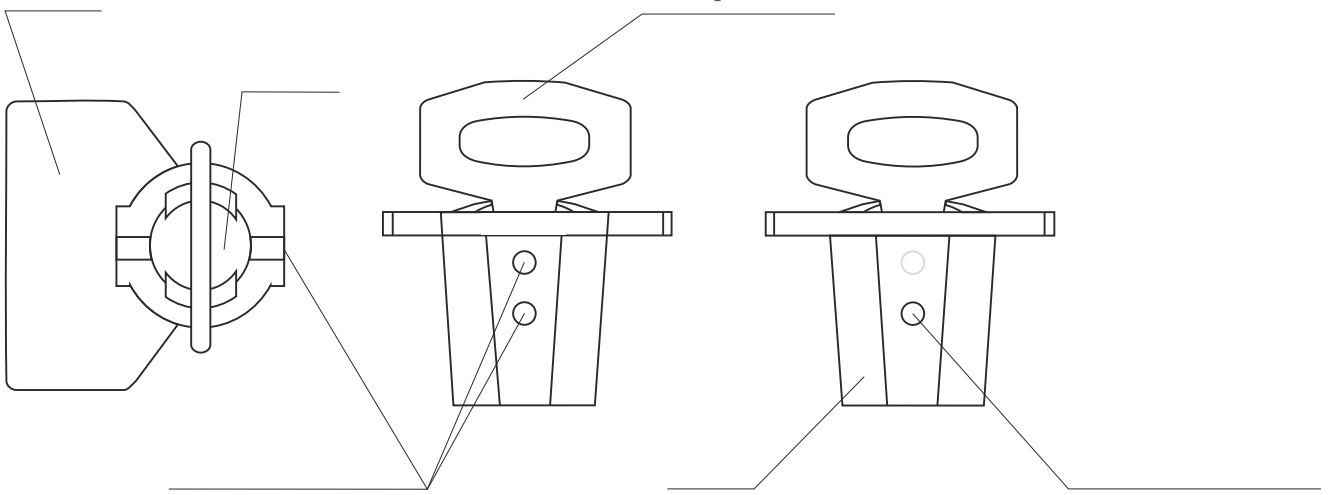

- 25.04.2012 . (390).
-
-

	-
	22 21,4 25,5
	- ; -
	-40 +60
	7 (), 4
	1 000
	0,65 0,9 - 0,80
	4 000 (8 500, 5)
	470 260 390
	10,4
(), .	1 000



- | | |
|--|---|
| <p>1. ()</p> <p>2. 360° ()</p> <p>3. 5 ()</p> <p>4.</p> <p>5. ()</p> | <p>1. ()</p> <p>2. () ()</p> <p>4.</p> <p>5.</p> |
|--|---|