



® - 3



« »,
7399-012-38993417-2010.
42512 43003.
31283-2004, . 6.3.3.,

7

1000

	/
	428
	345
	7,8
	-20 +60 -40 +60
	7-8 ()
	1 000 .
	1 000 .
	25 12
() , ()	40 (400)
	1 000 , 10
	550 220 250
	6,1
() ,	1 000

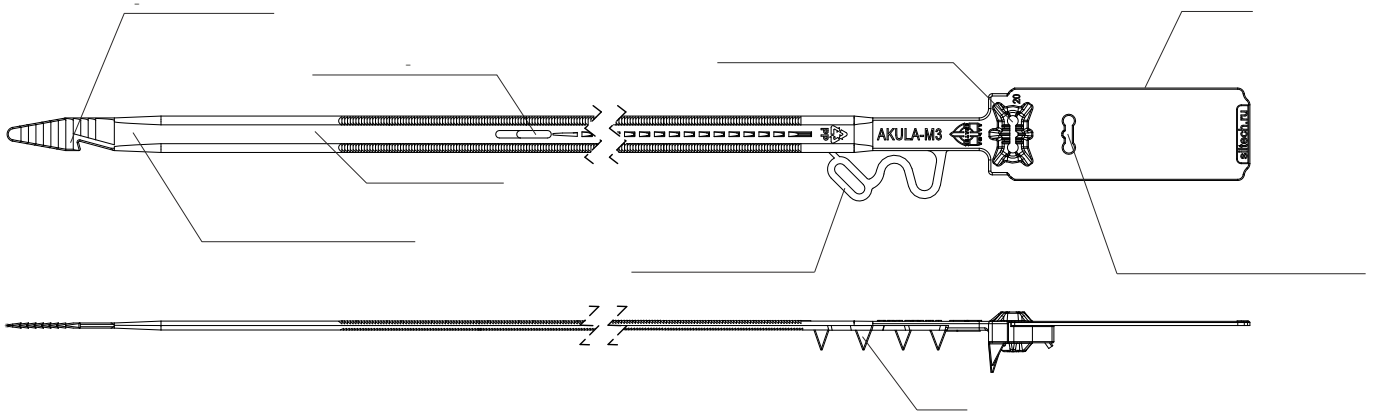

1. ()

+10°

1.

2.

3.

3.

4.

():

5.

()

4.

-

5.

6.

()